



URBAN OASIS CONSTRUCTION MANUAL

Arid Regions of Mexico

Implementada por

giz Deutsche Gesellschaft
für Internationale
Zusammenarbeit (GIZ) GmbH

**OASIS
URBANOS**

SOCIEDAD CIVIL NIPARAJÁ
Niparajá

URBANERÍA

**EPI
MÉXICO**

Published by

Deutsche Gesellschaft für
Internationale Zusammenarbeit (GIZ) GmbH

Registered addresses of the company:

Bonn and Eschborn, Germany

Project “Sustainable development of coastal urban areas through the integration of ecosystem services and biodiversity (BIOCITIS)”

GIZ agency in Mexico, Torre Hemicor, PH, Av Insurgentes Sur 826, Col. del Valle,
03100, CDMX

Mexico

+52 55 55 36 23 44

giz-mexiko@giz.de

VERSION

May 2023

DESIGN

DITHO Design GmbH, Cologne, Germany

TEXT

Manual written by: Sociedad de Historia Natural Niparaja A.C, Urbaneria A.C. and Ecology Project Mexico A.C. with the support of Deutsche Gesellschaft für Internationale Zusammenarbeit (GIZ) and the Instituto Municipal de Planeacion Los Cabos

Technical and content team/authors (in alphabetical order): Alejandra I. Campos Salgado, Alejandra M. Garcia Castro, Lucia Corral Aguayo, Marlu Robledo Mejia, Nicole A. Harmelin Garcia, Selene I. Vergara Segura

COLLABORATORS

Fondo Mexicano para la Conservacion de la Naturaleza; Secretaria de Desarrollo Agrario, Territorial y Urbano (Mexican Ministry of Agricultural, Territorial and Urban Development); project “Sustainable development of coastal urban areas through the integration of ecosystem services and biodiversity (BIOCITIS)” (GIZ Mexico); sector project “Cities” (GIZ), Alumbra Innovations Foundation

SPECIAL THANKS (IN ALPHABETICAL ORDER)

Many thanks for their contribution and help at all stages of the implementation of the urban oases and for all their assistance in the development of this manual to:
Ariel Gonzalez Montoya, Comprehensive Planning Coordinator, Instituto Municipal de Planeacion de Los Cabos; Barbara Scholz, Team Leader, Deutsche Gesellschaft für Internationale Zusammenarbeit (GIZ); Carolin Hoffmann, Technical Advisor, Deutsche Gesellschaft für Internationale Zusammenarbeit (GIZ); Rossana Landa, Coordinator of Projects and Strategic Alliances, Fondo Mexicano para la Conservacion de la Naturaleza; Silvia Salas, Head of the Representative Office, Mexican Ministry of Agricultural, Territorial and Urban Development

CONTACT INFORMATION

alianza.oasisurbanos@gmail.com

RECOMMENDED CITATION

Niparaja [1], Urbaneria, EPI Mexico [2], Urban Oases Construction Manual, Arid Regions of Mexico, Germany, 2023

FOTO DE PORTADA

@ GIZ Mexico, Josafat de la Toba

COMMISSIONED BY

The German Federal Ministry for Economic Cooperation and Development (BMZ)/
Alternatively: The German Federal Ministry for Foreign Affairs (AA)



PARTNERS OF THE URBAN OASES PROJECT



Index

The Urban Oases	8
What are Urban Oases and what benefits do they have?	8
The Principles of Urban Oases	9
The Components of Urban Oases	10
Nature-based solutions for preserving and restoring the basin	10
Community use and enjoyment of the space	11
How do you create an Urban Oasis?	12
1. Planning of the Urban Oasis	13
Participation of citizens and representatives of various sectors	13
Involvement of the community in the project	13
Involvement of government bodies	18
Selection of the site	20
2. Design of the space	22
Topographical survey	22
Social and environmental assessment	22
Participatory design of the public space (theory and practice workshop)	23
Architectural design	26
Executive project	26
3. Construction of an Urban Oasis	27
Reforestation with native vegetation (theory and practice workshop)	28
Green infrastructure (theory and practice workshop)	32
Construction of picnic areas (community use theory and practice workshop)	44
Adaptation in line with local regulations	44

4. Maintenance	46
Maintenance plan	46
Cost of an Urban Oasis	52

Annex	54
--------------	-----------

Annex 1 - The 12 criteria	55
Annex 2 - mulch	57
Annex 3 - pergola installation manual	59
Annex 4 - picnic table installation manual	61



This urban oases guide is intended for community leaders, citizens and professionals who wish to use urban oases as a strategy for improving the conditions in the basins and the conditions of life in general in the communities of the arid regions of Mexico.

The Urban Oases project arose from collaboration between the following organisations: Sociedad de Historia Natural Niparajá A.C. (Niparajá), Urbanería A.C. and Ecology Project International A.C. (EPI Mexico). Together, these organisations have more than 55 years of experience.



Through its “Water and City” programme, Niparajá is striving to create social and ecosystem resilience based on the well-being of the basins, a systemic approach, multidisciplinary collaboration and collective action.

URBANERÍA

Urbanería’s purpose is to return ecological functions to the city through the recovery and creation of public spaces together with the community, using green infrastructure, tactical urbanism and native trees.



EPI Mexico promotes the creation of sustainable communities in which young people have an active role through education based on the location, science and community participation. With the collaboration of local government agencies and foundations, it aims to address issues relating to the loss of permeable soil and the subsequent reduction in subsoil water infiltration.

The urban oases are intended to contribute to the preservation of the environmental and social services which the basins offer us. At present, the basins face a major challenge in relation to the population increase and the consequential growth in urban areas. This has brought about a deterioration in the soil and a reduction in vegetation and soil in the basins, transforming these previously permeable surfaces into eroded or impermeable surfaces (like tarmac, concrete and roofs) which impair the subsoil water infiltration. In Baja California Sur (BCS), the situation is particularly challenging, since rainfall is scarce and irregular, which means that practically no surface water is available, and the main source of drinking water is the aquifers (rain-water that infiltrates the basin and accumulates in the subsoil over the course of the years).

According to the World Resources Institute, BCS has the highest hydric stress of the entire country. Most of its aquifers are over-exploited, since water is being extracted from them more quickly than the rain can refill them. In addition, the state of BCS is extremely vulnerable to the adverse effects of climate change.

This means that the basin needs to be kept healthy so that the water can infiltrate the subsoil and the aquifers can be refilled. If, however, water falls on impermeable surfaces, it flows over these surfaces and floods buildings, streets and ditches as well as mixing with pollutants such as automotive oil, herbicides and animal faeces which subsequently reach and pollute the bays. Furthermore, the impermeable surfaces raise temperatures and cause the “heat island” effect whereby developed areas become warmer than nearby rural areas, resulting in higher energy consumption and air pollution.

→ The publication of this manual was assisted by the international initiative “Cities CHALLENGE 2.0” as part of an ideas contest on the topic “Building Vibrant and Resilient Neighbourhoods”. GIZ projects in Bangladesh, India, Mexico and South Africa took part with innovative planning and construction perspectives along with local, (inter) national partners and the local population. The four selected projects were executed as “urban living labs” from January 2022 to June 2023. In Mexico, the project “Our Resilient Neighbourhood” took place, resulting in an

urban oasis in the Parque Hundido Pedro Sánchez park in San José del Cabo. The lessons learned in this project form part of this manual.

For further information, please go to
→ city-transitions.global/citieschallenge



Building Vibrant and Resilient Neighbourhoods

The Urban Oases

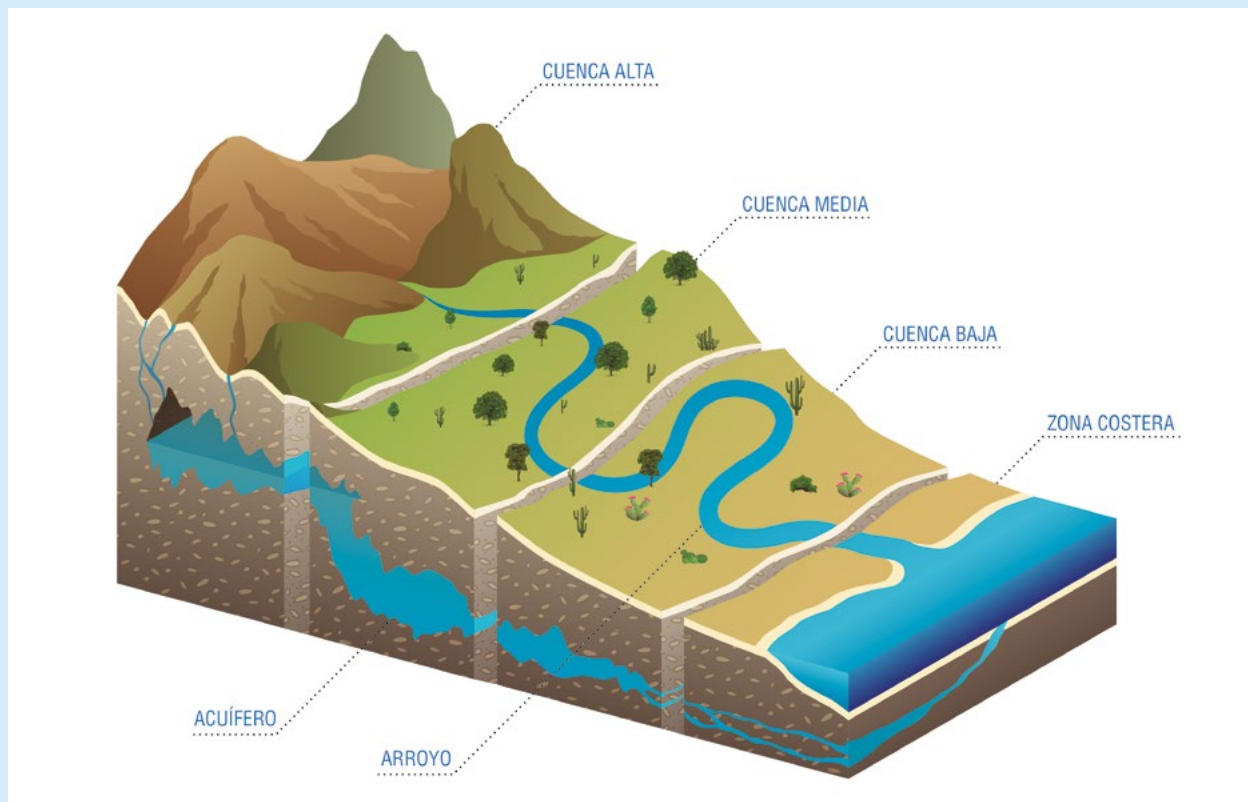

What are Urban Oases and what benefits do they have?

The urban oases are a nature-based solution which attempts to create multifunctional, safe and inclusive spaces which offer environmental and social benefits together with the community (experts, local residents, volunteers and the authorities).

The benefits of urban oases:

- They clean the rainwater. When the water flows into a ditch prepared with plants and mulch, the water pollutants are filtered out or decay by means of various processes.
- They can contribute to other objectives such as slowing down traffic and the safety of pedestrians and cyclists.
- They use soil and vegetation self-regeneration processes which do not require much maintenance.

- They provide passive irrigation for trees and other vegetation which, in turn, provide streets with shade and cool them down.
- They provide a wildlife habitat and connections between habitats.
- They make communities more attractive.
- The green infrastructure (GI) can help to improve stream conditions by capturing and treating the water from higher up in the collection basin. This can reduce erosion, pollution and the need for concrete gutters.

Limitations:

- They do not always provide large-scale flood control.
- They cannot remove heavy metals from the water.

The Principles of Urban Oases

When constructing an urban oasis, two fundamental principles must be considered: **The inclusion of the community and the multifunctional purpose of the space.**

With regard to the **inclusion of the community**, it is important that the construction process involves a wide range of participants such as local residents, businesses, schools, community groups and more. This can be achieved by means of theory and practice workshops during which the benefits of urban oases are discussed and the community can be allowed to participate actively in the design, construction and maintenance of the space. When the community is involved in the entire process, members of the community develop a sense of ownership and responsibility which can help to sustain the space in the long term.

In addition, it is important to point out that the inclusion of the community can also encourage the use of the space. The development of a sense of ownership and belonging can motivate the community to organise activities which promote the use and enjoyment of the urban oasis.

With regard to their **multifunctional purpose**, urban oases must be designed in a way which offers a wide range of benefits for society and for the ecosystem. Some of the functions which they can perform include providing a space for recreational activities, relaxation and social cohesion. They can also help to preserve the environmental services of the basin and can contribute to education, health and aesthetics, amongst other things. The urban oases are able to assimilate these functions in various ways (→ Table 1), maximising their usefulness and the benefits to the community.

Function	How the function is assimilated at the urban oasis
A space for recreation, relaxation and social cohesion	The space is designed together with the community and in accordance with the community's requirements so that it can be used for relaxation and recreation. These spaces and the relaxation areas which are built encourage the designation of meeting points which facilitate social cohesion.
Preservation of the environmental services of the basin	Nature-based solutions are created on the basis of green infrastructure and native vegetation.
Education	The entire urban oasis implementation process involves the participation of citizens through theory and practice workshops. In addition, signs are displayed with information about the urban oases and the native vegetation to raise awareness amongst visitors.
Health	Areas encouraging exercise and recreation and facilitating mental health are created.
Aesthetic value	The space is designed to be visually appealing, inviting people to visit and enjoy the oasis.

Table 1: The assimilation of multiple functions at an urban oasis

Liveability of the space

It is vital that the areas chosen have the necessary characteristics to ensure the safety and satisfaction of their users, so that they can be transformed into ideal places for gatherings and a range of activities for local residents.

The Components of Urban Oases

Urban oases have two main components: **The first is the ecosystem**, which is associated with the construction of nature-based solutions which use the green infrastructure, native vegetation and physical elements of the soil to preserve and restore the basin; **the second is the social aspect**, which is associated with the involvement of the community in the construction of the urban oasis and in the use and enjoyment of the space.

Nature-based solutions for preserving and restoring the basin

Green infrastructure The green infrastructure (GI) offers a comprehensive solution for the management of rainwater by distributing it within the urban zone rather than directing it away from the site as quickly as possible as is achieved by the grey infrastructure.

→ The GI is composed of structures which use living, natural systems to provide environmental services such as the preservation of soil, the containment, cleaning and filtration of rainwater, the creation of wildlife habitats, and the provision of shade for and the cooling down of streets and buildings.

Native vegetation The project encourages the preservation and/or reintroduction of native and endemic species which are adapted to the physical conditions of the site (including adaptation to scarce and variable precipitation). In general, the vegetation – particularly native vegetation – fulfils its function and does not require any additional irrigation once established; it is adapted to the environmental conditions of the region. On the other hand, these species, in addition to providing better environmental services in the long term, facilitate the enjoyment of the space and the creation of identity through the forging of a connection to the natural environment. They also fulfil the following functions:

- Remove pollutants from the air and rainwater
- Provide shade and encourage refreshing evapotranspiration, thus reducing local temperatures as they shade surfaces
- Lengthen the lifetime of tarmac by providing shade
- Provide a wildlife habitat
- Form organic material in the soil
- Increase the permeability of the soil through root penetration
- Absorb atmospheric carbon dioxide
- Prevent soil erosion
- Keep paths in good condition

Utilisation of the physical characteristics of the soil We use the structure of the soil to redirect the water so it can infiltrate the subterranean aquifers.

Community use and enjoyment of the space

The urban oases attempt to restore the urban fabric by cleaning up and recovering green areas and providing natural, liveable and safe spaces accessible by all citizens. In addition, the needs of the community are taken into account with regard to the use and enjoyment of the oases. This might include workshops, meetings, an information centre and areas for sports etc.

To strengthen the ties between the community and the space, it is recommended that a community committee be formed from representatives of the authorities and local residents. The members should work together on the design and execution of the urban oasis construction project and on organising activities to ensure that the space is used and continues to function as intended.

A space adapted to specific needs

- Materials which already exist at the site are used, such as tree trunks and rocks which can improve slope conditions and make the space suitable for use by the community.
- Areas are created to allow users of all ages to enjoy the space and use it for various activities. This is done by building furniture which encourages social cohesion, using the shade of trees and structures to allow more time to be spent in the spaces, and creating safe crossing points, amongst other things.
- Urban art is used to enhance the space.

Safety

So that the entire community, including women and children, can visit the public space safely, we must be sure that they do not feel at risk. It is important to make sure that the area has light and open spaces (this must be taken into account both in the design of the project and for maintenance measures such as the pruning of trees). This ensures good visibility when walking around the space, and avoids creating corners which can be used as hiding places. Collaboration between the community and the authorities makes it more likely for the space to be kept in an adequate condition and encourages members of the community to visit it.

Liveability of the space

The public space should have characteristics which offer conditions of safety and comfort and which invite visitors to organise various activities in the space, so it is not used merely as somewhere to pass through on the way to somewhere else but as a meeting place for local residents.

How do you create an Urban Oasis?

This guide is based on the experience of Alianza Oasis Urbanos in the successful implementation of projects at various locations in Baja California Sur in collaboration with local government agencies. The design specifications presented here facilitate the understanding of the concepts and must always be adapted to the specific conditions of each location and to governmental regulations.

The participation and joint collaboration of citizens, local government agencies and other relevant bodies is essential for the construction of an urban oasis at all stages of the project, including the following:

1. Planning of the urban oasis	13
Participation of citizens and representatives of various sectors	13
Involvement of the community in the project	13
Involvement of government bodies	18
Selection of the site	20
2. Design of the space	22
Topographical survey	22
Social and environmental assessment	22
Participatory design of the public space (theory and practice workshop)	23
Architectural design	26
Executive project	26
3. Construction of an urban oasis	27
Reforestation with native vegetation (theory and practice workshop)	28
Green infrastructure (theory and practice workshop)	32
Construction of areas for community use (theory and practice workshop)	40
Signs	44
Adaptation in line with local regulations	44
4. Maintenance	46
Maintenance plan	46

Planning of the Urban Oasis

Participation of citizens and representatives of various sectors

The participation of various sectors is vital for the successful implementation of an urban oasis. It is essential for both the community and local government to be involved at all project stages from planning right through to the maintenance of the space. In addition, the involvement of civil society organisations, academia and specialists who can contribute their knowledge in various areas and specific activities is recommended. The combination of various skills and functions to create a common vision will bring about the sustainability of urban oases and will allow them to be replicated in other locations.

Involvement of the community in the project

In order to achieve the effective involvement of the community in all urban oasis project phases (planning, design, construction and maintenance), it is vital to encourage local residents to see the urban environment as their own space and to strengthen the social fabric.

This can be done by implementing “recruitment” campaigns using mechanisms which enable the formation of a group of interested local residents who are willing to collaborate in the creation of a shared vision and then to turn that vision into reality. To encourage them to get involved, it is important to clearly and effectively communicate the process which will take place during the course of the project, highlighting the learning experience. Moreover, an atmosphere of coexistence must be fostered in order to invite people to form part of the project. There are various ways to recruit people interested in taking part.



Phase 1: Recruitment

During this phase, members of the community around the future urban oasis are contacted in different ways and posters are designed to raise awareness about the project.

Ways of contacting potential recruits

- **WhatsApp group:** WhatsApp lets you create a group and generate a direct access link to invite people to join it. It must be easy for local residents to identify the group in question. For example, it might make sense to use the name of the park or community and the name of the project. This medium can be used to directly contact people who are interested in taking part.
- **Facebook group:** Social media networks enable contact with established groups which are associated with the community in question, e.g. marketplace groups. When you join a group of this kind, you can make contact with the administrators and ask for help, post an invitation and add people to the project WhatsApp group.
- **Design of flyers:** Flyers can be distributed via Facebook, Instagram and WhatsApp to announce meetings/workshops and to share QR codes and links to the WhatsApp group. They can also be printed out and placed in places near the park so that users and local residents who do not use social media are also able to get involved with the activities.
- **Groups of teachers and families of schoolchildren:** Local schools can be identified and asked to share the invitation to the WhatsApp group in groups for teachers and the families of their students.

Dissemination of information with a visual identity

It is important to have a visual identity which allows interested parties to quickly perceive that the presented information is about the project to be carried out. This identity can be used on flyers, in social media networks and in WhatsApp groups.

Phase 2: Call for Participation

During the call for participation, interested parties are invited to take part in an informative talk about the project.

Phase 3: Consolidation

During this phase, the first meeting with the community takes place in the form of an informational meeting, and a project promotion group is identified.

First meeting with the community

- **Virtual meeting:** The first meeting can take the form of a Zoom or Google Meet meeting if this is convenient for the community. The meeting involves introducing the team interested in creating the urban oasis, presenting the project and talking with the participants. This session can help to identify key persons who might be able to help to raise awareness of the WhatsApp group and participatory workshop among local residents.
- **Planning of face-to-face meeting:** It is recommended that a questionnaire be distributed via the WhatsApp group to determine the most convenient day and time for the majority of participants to attend an initial face-to-face meeting. It is also useful to promote the meeting by means of a flyer containing information on the general activities of the workshop, including special activities for children and a shared snack of pizza (everyone loves pizza!).

Promotion group:

To encourage community participation during the course of the project, it is important to identify community leaders who can inspire others to take part. One option is to create a community committee.

Community committee:

If the community has an active local residents' committee, it is recommended that this committee be contacted and invited to form part of the project right from the start. If not, it is suggested that a committee be created by inviting the authoritative bodies responsible for citizen participation in the community in question to establish a community committee made up of residents local to the urban oasis. This committee must be formed democratically and must be organised, independent, voluntary and honorific. A general assembly must be held to define participation mechanisms and a work plan for the monitoring and execution of community actions and suggestions arising from the participatory process. It is recommended that the participation of children, adolescents, young adults and women be prioritised, since these are the groups which, statistically, make more use of public spaces.

The strength of a community committee lies in its continuity, since local governments change but the community tends to persist in the long term. Since it is the community which will directly benefit from the presence of an urban oasis to use and enjoy, it is important to make members of the community aware of the role that they play and the impact of their actions when it comes to keeping this public space in good condition. This means that it is vital to strengthen the processing of teaching and learning so that the people involved see themselves as active agents of change.

Phase 4: Communication channels

A channel for communicating with the community (promotion group) must be kept open constantly during the entire course of the project.

TALLER DE VERANO EN EL PARQUE HUNDIDO

• INFRAESTRUCTURA VERDE Y REFORESTACIÓN
• PINTA DE MURALES



¡NO FALTEN!
Miercoles 20 y Jueves 21 de julio de 9 a 11 am y de 6 a 9 pm
Habrá bebidas y botanas.

Próximos talleres - Carpintería y urbanismo táctico.

MI BARRIO RESILIENTE  OASIS URBANOS



TALLER DE CARPINTERÍA EN EL PARQUE HUNDIDO



¡NO FALTEN!
Julio 25 de 6-9pm, 26 y 27 de 9-11am y 6-9 pm y 28 de 9-11am
Habrá bebidas y botanas.

Aprende a construir una pérgola que capta agua de lluvia y una banca de picnic

MI BARRIO RESILIENTE  OASIS URBANOS



TALLER DE PINTA DE CRUCES PEATONALES EN EL PARQUE HUNDIDO



¡NO FALTEN!
del 1 y 2 de AGOSTO de 5 a 9 pm
Habrá bebidas y botanas.

Además terminaremos de construir el mobiliario, pintaremos murales y reforestaremos con plantas nativas.

MI BARRIO RESILIENTE  OASIS URBANOS

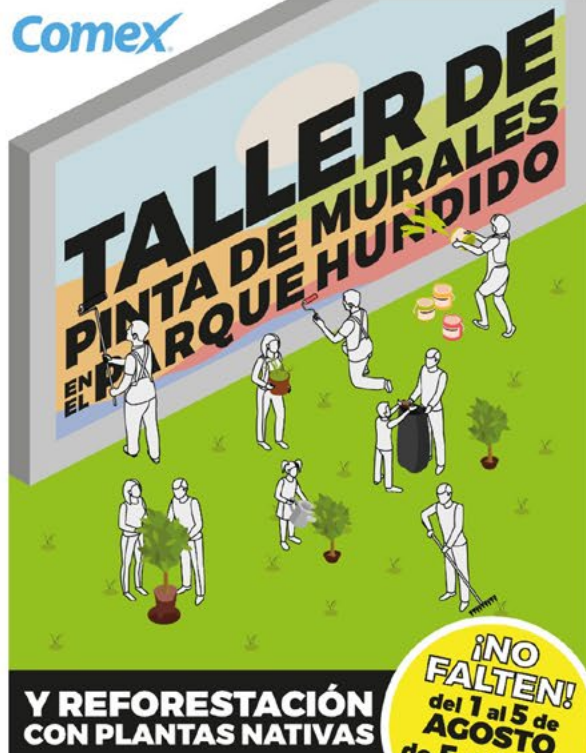

¡NO FALTEN!
del 1 al 5 de AGOSTO de 5 a 9 pm
Habrá bebidas y botanas.

Y REFORESTACIÓN CON PLANTAS NATIVAS

MI BARRIO RESILIENTE  OASIS URBANOS



A set of flyers designed with the aim of inviting the community to participate in the park project. They all have the same look&feel so that they can be easily identified as belonging to the same project. The titles and design of the flyers reflect the different topics handled in the various theory and practice workshops: Green infrastructure, carpentry, the painting of pedestrian crossings and the painting of murals. ©Alianza Oasis Urbanos

INVOLUCRAMIENTO COMUNITARIO Y ACTORES

PARA LOS

OASIS URBANOS

Etapa 1 RECLUTAMIENTO



Etapa 2 CONVOCATORIA



Etapa 3 CONSOLIDACIÓN

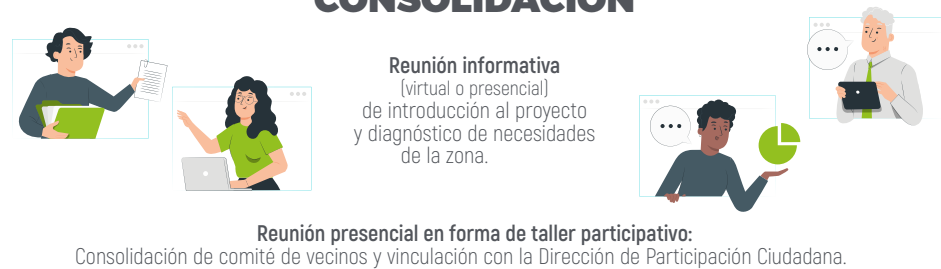

Etapa 4 CANALES DE COMUNICACIÓN



Involvement of government bodies

It is vital that the local authorities be involved right from the start of the project in order to ensure ongoing public ownership of the selected site. Without legal certainty, there is a risk that intervention measures might be privatised in the future, restricting the participation, use and enjoyment of the space by the community.

In addition, the technical opinion of the local authorities is essential to ensure a stronger project, since these authorities have knowledge in this area and are able to inform project participants about possible regulatory restrictions. They can also help with administrative formalities such as licences, permits, building approvals and environment permits as well as other applications required to realise the project.

It is crucial to forge links between the community and the local authorities. This requires the involvement of both the technical authorities and the authoritative bodies responsible for citizen participation in cultural and sporting activities. Citizen participation areas can reinforce the recruitment of community members for participation in workshops and various activities during the realisation of the project as well as in other activities which will be organised once the urban oasis has been finished.

In order to ensure that the urban oasis continues to function as intended, the local government and the community (through the community committee) must work together on activities relating to cleaning and maintenance and must encourage different activities which keep the space in active use.

In particular, it is vital to involve the Municipal Public Services area, which is responsible for preserving, enhancing, maintaining and cleaning green areas, parks, gardens and the central reservations in the local area. In addition, they coordinate measures to keep the local public street lighting system in operation and perform reforestation work, amongst other things. The Municipal Institute of Planning (IMPLAN) must also be involved. IMPLAN can support the project by bringing together various areas of government and citizens, giving continuity to municipal plans and programmes, and helping with certain permits which are required to comply with local legislation.

Involvement of other sectors and specialists

Civil society organisations can participate in the project by becoming involved with specific issues such as the water cycle, importance of the basins, native vegetation, urban art, citizen science and many other areas of interest. The world of academia can act as the driver of scientific research and the monitoring of the space.

During the course of the project, the fact that the help of specialists will be required for various topics and activities must be borne in mind. For example, when selecting the site, they will be involved in the architectural design, soil topography, construction work and other areas.



Presentation of awards to the promotion group and personnel from Municipal Public Services in recognition of their involvement and commitment during the course of the project ©GIZ Mexico, Josafat de la Toba



Personnel from Municipal Public Services who took part in workshops ©GIZ Mexico, Josafat de la Toba

Selection of the site

Various criteria, which depend on the project objectives, must be considered when selecting the site where an urban oasis is to be built. The objectives will also dictate the number of criteria applicable to the selection of each space. The criteria to be considered when selecting the site include the following:

- Legal certainty with regard to the public ownership of the site, with the objective of ensuring the perpetual use and enjoyment of the space by the community
- Adequate run-off so that vegetation does not require irrigation in the long term
- Existing vegetation and the benefits it offers
- Ecosystem diversity
- Crime rate
- Population density and diversity

- Site accessibility (physical access and availability of permits for the work)
- Lighting and availability of water
- Community partners in the area (this could be an organisation, institution or a community leader)
- Evidence of effort or active community participation, preferably in the area itself, in order to ensure social involvement and the maintenance of the space in the long term
- Support from the local government for the realisation of the project
- Assured source of funding for the maintenance of the space

An analysis which describes and identifies the characteristics of the site must be carried out. In addition, the surrounding area must be analysed visually, identifying nearby areas of importance.

→ Analysis of the park

Flat land: The ground has been eroded by rain and wind. There is practically no vegetation except for some palm trees and a few shrubs. There are areas which are very exposed to the sun and without an activity programme. These areas can accommodate structures, furniture and amenities etc.

Land with a gradient: This characteristic can be found all around the perimeter of the park. Because of the lack of vegetation and green infrastructure techniques, the soil is eroded.

Land with native vegetation: The park is clearly divided into two parts: One with more infrastructure and the other which has remained undeveloped, allowing the native flora to develop freely.

Primary access: These are the points of access which clearly invite people to enter the park via paved paths.

Informal access: Since there are only two formal points of access on one side of the park, the users have created their own access points on the opposite side.

Areas which feel unsafe to traverse: In the part of the park where the wild garden can be found, visibility is not great due to the sloping ground on which it was built and the unchecked undergrowth. Assaults have taken place in the area, and people do not feel safe here.

Informal pathways: Recently, the needs of users have caused paths to be forged in areas without infrastructure.

Areas open to intervention: These areas are spaces with physical characteristics, means of access and dimensions which are favourable to the development of an activity programme.

Areas with a pronounced slope: Slopes which have remained fully vulnerable to erosion caused by climatic conditions due to a lack of vegetation. Such areas pose a serious problem for the integrity of the park.

Waterlogged areas: These areas can be found at the lowest level of the park by the low flood barriers. They serve no useful purpose.

Physical and visual barrier between the two parts of the park: At the lowest part of the park, flood barriers were used to mitigate the effects of flooding as the basin descends. There is no guarantee that this method will provide good results, but it divides the park as a whole in a visual and physical manner.

Structures: There are two structures in a state of abandonment. One of these is a square sheet metal structure which served as a shop before the pandemic. It is surrounded by a structure whose construction was suspended due to the lack of a permit. The other is a circular metal fence.

Infrastructure damaged by erosion: Paths and poured concrete steps where it can be seen that erosion has affected the structural foundations.

Example of an analysis with a description and identification of site characteristics

ANALYSIS

ANALYSIS/DIAGNOSTIC PLAN

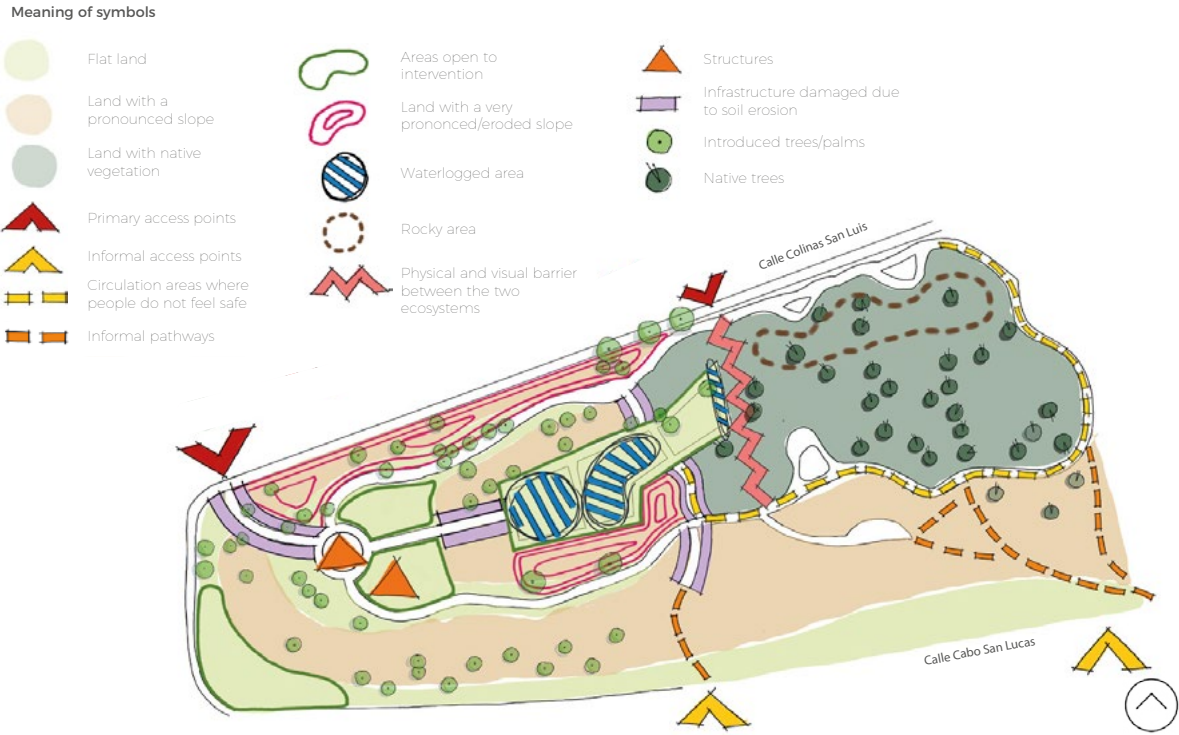

Example of a visual (diagnostic) analysis ©Alianza Oasis Urbanos.

2. Design of the space

Topographical survey

First, a study of the chosen site must be performed in order to determine the topography, the natural water course and the areas most suited to intervention. This study is then used to establish an architectural programme for the construction of an urban oasis which specifies the work to be performed, the area in question and the objective.

Social and environmental assessment

The social and environmental assessment aims to gather the information necessary to analyse the current conditions of the city and community where the creation of the urban oasis is planned. To do so, it is important to focus on identifying environmental and social characteristics of the communities adjacent to the site in order to make decisions, during the design and implementation of strategies, which reflect the social and environmental conditions of the community in which the work will be taking place.

The elements to be analysed include the following:

- Social composition
- Climate
- Air quality
- Geographical location
- Adjacent communities
- Current problems
- Current condition of the site from the social perspective of local groups

Additionally, the investigation for the assessment requires two phases: 1. Documentary research into the economy, population and social/environmental conditions in the area; 2. Interviews with residents local to the park and familiarisation with the space by inspecting it and asking people to answer questionnaires about it.

Participatory design of the public space (theory and practice workshop)

The aim of the design process is for the participants to:

- Familiarise themselves with the project and with other involved parties
- Inspect the space, familiarise themselves with the objective and share their vision in order to create a joint plan for the park
- Come together as a group of volunteers/local residents and learn about future activities and workshops as part of the project

The activities of the theory and practice workshop for the participatory design process can be divided into the following phases:

- **Presentation and motivations:** In a group activity, the participants introduce themselves and explain their reasons for participating in the workshop. Questions can be asked to get the conversation going, e.g. “How long have you lived in this area?” “What are your favourite parts of the park?” “What would you like to improve?”
- **Reconocimiento del lugar.** The community needs to observe the area in detail and identify the places which receive the most and the fewest visits and the reasons for this. It is also important for them to state how they feel when they visit these places or when they choose to avoid them. A map printout with symbols which represent the places with receive the most and the fewest visits (+ and -) and emoticons (😊), which express the emotions of the participants can be used to share this information with the group of workshop participants as a whole. It is a good idea to have stickers prepared with the relevant symbols so that participants can stick them onto the map.
- **Excursion:** This activity takes the form of a walk with the purpose of analysing the spaces. It makes sense to use the 12 quality criteria from Jan Gehl’s “New City Life” for determining a good public space. This method involves walking through the park and stopping at key points identified on the site familiarisation

map drawn up by the local residents, observing these spaces thoroughly and answering the questions from the 12 criteria questionnaire (Annex 1) in order to evaluate them. The participants must evaluate each criterion at the actual site (this can be done with a scale or with emoticons). It makes sense for the organisers of the excursion to take notes of comments made by local residents and to take along their own map for specific notes. This activity can be shared between teams depending on the number of participants.

- **Vision:** This phase intends to give the community the chance to communicate what they would like their park to have. Depending on the number of participants, it might make sense to divide the group into teams so that everyone gets the chance to put forward their ideas (small groups offer a higher chance of everyone getting the chance to speak). During the vision activity, it is important to stress that the budget is limited. However, it is also important that participants can voice all of their ideas, since more funds might be obtained later on or the residents themselves might get together in order to achieve this. The information from the vision must be visualised by each of the teams on a map. The use of drawings (e.g. Post-It© notes) and stickers etc. is recommended.
- **Final map with the assimilated community vision:** Each team presents its vision and the best options are illustrated on a joint map. If the space is large, the vision can be agreed by zone: Votes are held for each zone and the information is brought together on the final map.
- **Next steps:** Once the final vision has been visualised, the community must be told about the next steps so that they are able to participate.



Team working on the identification of what features they would like their park to have during the vision phase of the participatory design process ©Alianza Oasis Urbanos



Pre-intervention **excursion** phase with residents local to the park ©Alianza Oasis Urbanos



Community filling absorption well with material ©GIZ México, Josafat de la Toba.



Presentation of the final map with the assimilated community vision @Alianza Oasis Urbanos.

For this process, a space which encourages the comfortable coexistence of the participants must be provided. Food can be a good way to bring about communication between people, and can also provide a fun closing activity after the excursion. A simple meal is recommended so that it can be eaten outside and with the hands.

The following materials are recommended for this process:

- 90x60 printouts of the park for affixing the information relating to familiarisation with the site
- 90x60 printouts of the park for affixing the information relating to the vision (one for each team)
- Worksheets for the 12 criteria (one worksheet per team)
- Post-It®s so that the participants can stick what they want onto the map

Architectural design

Once those community needs which can be included in the urban oasis in accordance with the scope of the project have been identified, the architectural design process takes place. This must include creating the set of plans and specifications, drawings, details and perspectives which will enable the realisation of the urban oasis, including the allocation of all of the spaces and finishing touches included in the implementation.

Executive project

The executive project includes all of the elements necessary and adequate for the full execution of the works, including the zoning, general objectives, project scope, architectural design, cost estimates, activity programme and all of the data and details allowing the relevant professionals in the various sectors to carry out their work.

3. Construction of the Urban Oasis

The participation of the promotion group, community committee, local authorities and population in general is essential for the successful construction of the urban oasis. It is therefore recommended that these groups be involved in theory and practice workshops on topics relating to the project, such as:

- Reforestation with native vegetation (theory and practice workshop)
- Green infrastructure (theory and practice workshop)
- Areas for communal use: Urban furniture and art (theory and practice workshop)
- Signs to promote learning (theory and practice workshop)

Equally, it is important to hold workshops that raise awareness about relevant topics, e.g. about water management, recycling and the importance of citizen participation. The community might be interested in learning information of this kind and sharing it with other people.

In order to ensure a high level of participation in the workshops, a flow of theoretical and practical knowledge must be encouraged through activities which are fun, interactive, creative, flexible and educational. It is also important to promote a sense of belonging, pride and contentment so that participants continue to contribute to the improvement of the site.

The climate should be taken into account when planning workshops, taking care to schedule them for months when it is likely to be comfortable to work outside without excessive heat, storms and other weather events which might reduce community participation.



Workshop to raise awareness about water management ©GIZ Mexico, Josafat de la Toba.

Reforestation with native vegetation (theory and practice workshop)

Planting sites should be planned with due consideration of the size of the vegetation when it reaches maturity in order to avoid excessively dense landscapes and plants which have to compete for resources or invade adjacent spaces (causing disruption to streets, curbs and power cables). These plants require constant pruning.

Selection of plants and choice of planting location

Plants must be planted in accordance with their relationship with water. During storms, water will remain in bioretention areas for up to several hours. As a result, the trunks and stems of various desert trees and plants can rot if they remain in water for a long time or if they are surrounded by damp mulch for a long time.

Trees Trees should be planted on elevated ground, since their extensive root systems allow them to reach water far beyond the reach of their leaves. It is important to remember that they require more water than other plants, and irrigation might be required in areas without significant run-off from hard or paved surfaces.

Shrubs These plants provide an excellent habitat, flowers, fruit and seeds for native birds, insects, reptiles and mammals as well as reducing erosion by protecting the surface of the soil. Shrubs are best planted on slopes of ditches/hollows or on raised platforms just above flood elevation where they are sufficiently low for their roots to reach the moisture in the soil but not low enough to be flooded for long periods of time.

Cacti, agave plants and yucca plants The flowers and fruit of cacti and succulent plants are important sources of nourishment for a variety of fauna. They must be planted together with trees and shrubs, since they do not contribute much to filtering rainwater or building soil. They must be planted above flood elevation in bioretention tanks. They require very little water and can be used in zones which do not receive extra run-off from hard surfaces.

Grasses Grasses create dense networks of stems and roots which effectively filter pollutants from rainwater, reduce erosion and increase the filtration of water down to the subsoil.

Wild flowers These plants provide important sources of nourishment to pollinators such as hummingbirds, bees and butterflies. Since they have variable tolerance to flooding, it is important to take information provided by local experts into account.

Small plants at soil level Some perennial wild flowers and shrubs can be used to cover the soil in order to protect it and retain the organic mulch. Since these plants have variable tolerance to flooding, it is important to take information provided by local experts into account.

PLANTING IN ACCORDANCE WITH TERRAIN HEIGHT

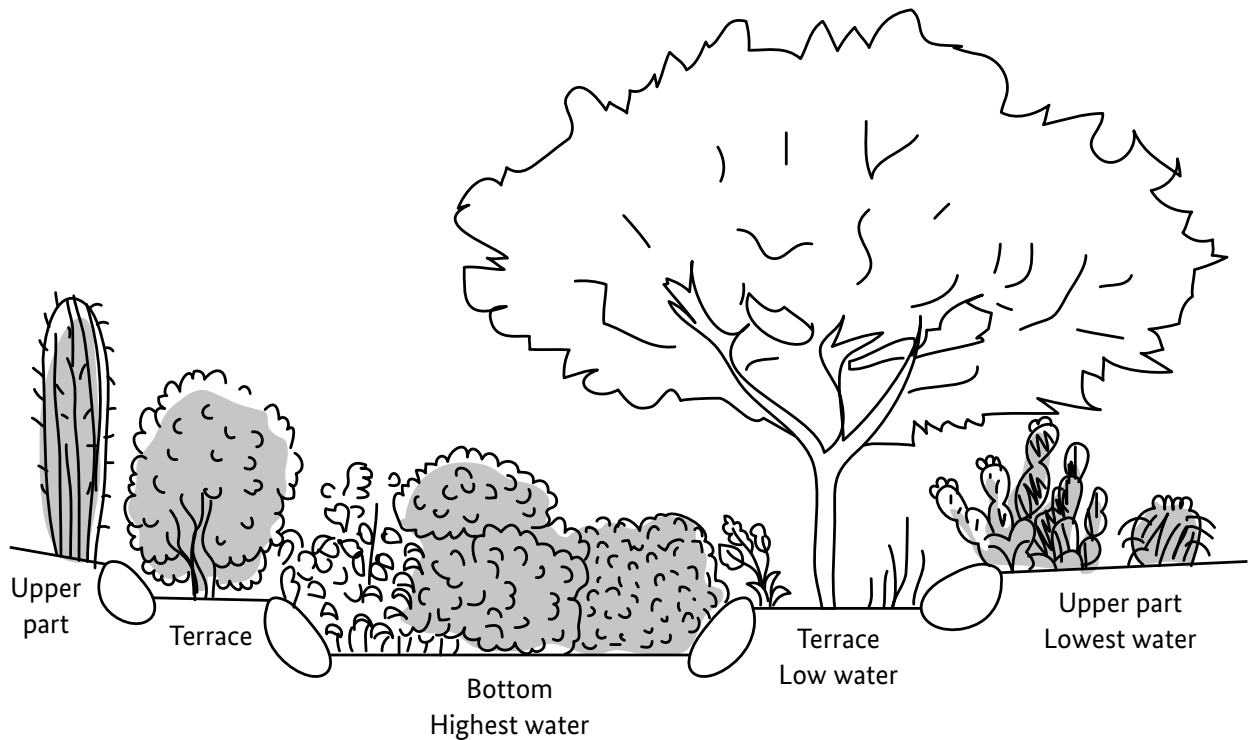

Diagram demonstrating what to plant in accordance with terrain height ©Alianza Oasis Urbanos

Reforestation

- Obtaining items for reforestation: Once the species to be planted have been identified, they can be purchased from garden centres, or the help of the town council and the Forestry Development Office can be requested in order to obtain native plants. As mentioned in the section on planting, planting must be organised in accordance with terrain height.
- Theory and practice workshop with members of the community: At this workshop, participants learn to identify species and plant them. They identify species using the vegetable palette and native vegetation identification guide, both of which can be purchased from Sociedad de Historia Natural Niparaja A.C. A digital version of the vegetable palette can also be downloaded here: → <https://issuu.com/niparajaac/docs/final>. With this purpose in mind, the participants can be split into small groups which work together to identify the species. Members of the community also participate in

the planting process, working together to break up the earth and make holes at the necessary depth for each plant. Once this is done, they plant the vegetation. Afterwards, the plants must be watered. Close attention must be paid to where water accumulates.

- Irrigation: The reforested plants will require irrigation, especially during the first few months after planting. This is because they need to establish their roots in the soil and develop a system which allows them to adequately absorb water and other nutrients. However, the type and frequency of irrigation will depend on factors such as the climate, plant species and soil type. It is vital to perform monitoring and checks on the amount of moisture in the soil to make sure that the plants receive a sufficient amount of water. Drip irrigation is an excellent option, since this is an efficient and sustainable way of watering plants with a range of benefits. Among these is the fact that

water consumption is reduced because the water is supplied to the roots of the plants in a very precise manner, and is not wasted on areas which do not need it. It also reduces soil erosion, improves soil quality and increases the efficiency of used fertilisers. In addition, it can decrease the cost and working time required to water the plants, since the irrigation system can be easily automated and controlled. Alternatively, *Lluvia Sólida*® (Solid Rain) can be used to increase the likelihood of success, since this solution keeps the roots of plants moist for a longer period of time. *Lluvia Sólida*® (marketed by a Mexican company) is a potassium-based

granular powder which is biodegradable, insoluble and non-toxic. It expands when it comes into contact with water and can absorb up to 400 times its weight in water (depending on the soil type, water quality, climate and plants etc.). This product can be used for all types of plants, crops, trees, gardens, potted plants, hydroponic plants and vegetables etc. The plants take up the moisture in accordance with their needs, which allows them to enjoy stable and healthy growth as well as reducing irrigation frequency. The system also optimises the use of rainwater by the plants. (For more information, see: → <https://lluviasolida.com.mx/>).



Reforestation with the community ©GIZ México, Josafat de la Toba.



Vegetable palette ©GIZ México, Josafat de la Toba.



Reforestation with the community workshop ©GIZ México, Josafat de la Toba.



Theory and practice workshop for identifying vegetation with the community © GIZ México, Josafat de la Toba.

Green infrastructure (theory and practice workshop)

Theory and practice workshops with the community are used to construct various kinds of green infrastructure. In this guide, we explain how to construct micro-basin gardens, “boomerangs” and absorption pits:

→ **Micro-basin garden**

Micro-basin gardens are an economical way to capture rainwater. They take the form of hollows in the terrain at a lower level than adjacent surfaces. This technique can be used in permeable areas and in zones close to imper-

meable surfaces such as roads and car parks. If they are constructed in such zones, cuts must be made in the curbs to allow water to flow into the ditch where the garden is located. If these gardens are created during new road works, the cost is comparable to that of creating ordinary flowerbeds. Generally speaking, this is a low-cost method which can be used in any permeable area.



Workshop on the creation of green infrastructure ©GIZ México, Josafat de la Toba.



Clearing ground for the creation of a micro-basin ©GIZ México, Josafat de la Toba.



Selection and movement of material for the creation of a micro-basin ©GIZ México, Josafat de la Toba.



PLANTING IN ACCORDANCE WITH TERRAIN HEIGHT

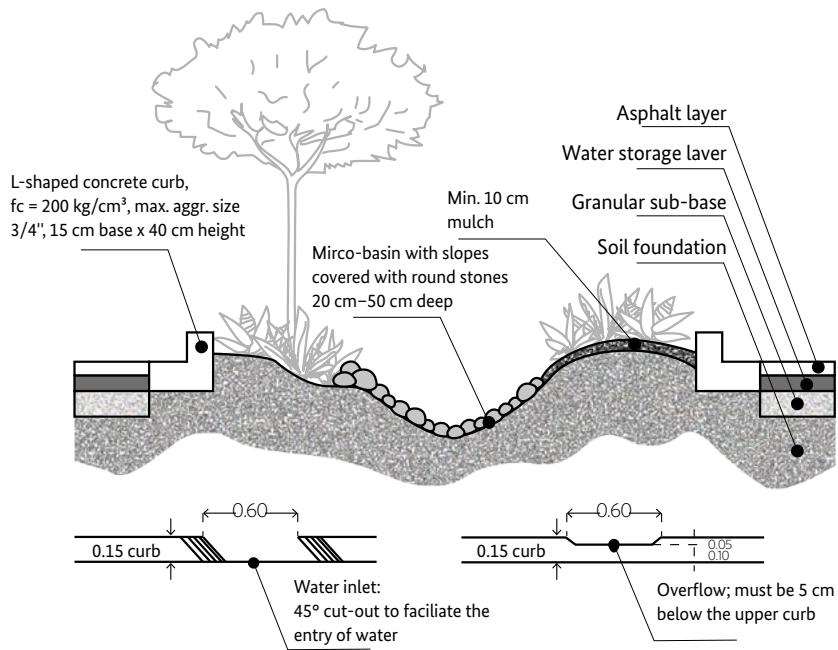
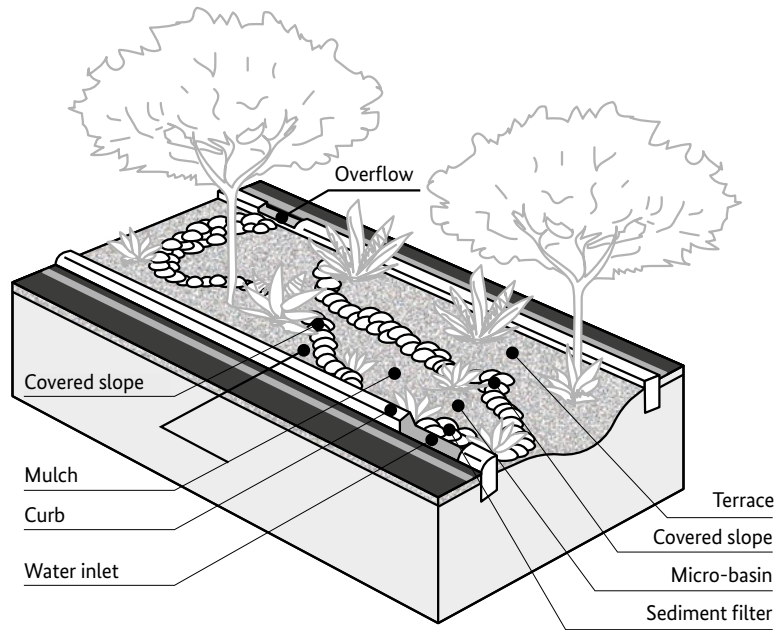

Micro-basin garden specifications ©Alianza Oasis Urbanos.

→ **Boomerang**

Usually, a “boomerang” is a piece of curved wood which is thrown and returns to the thrower. However, in this case, it is something

designed to intercept rainwater flowing down a slope, causing it to infiltrate the soil and the area where the roots of vegetation can be found.

BOOMERANG

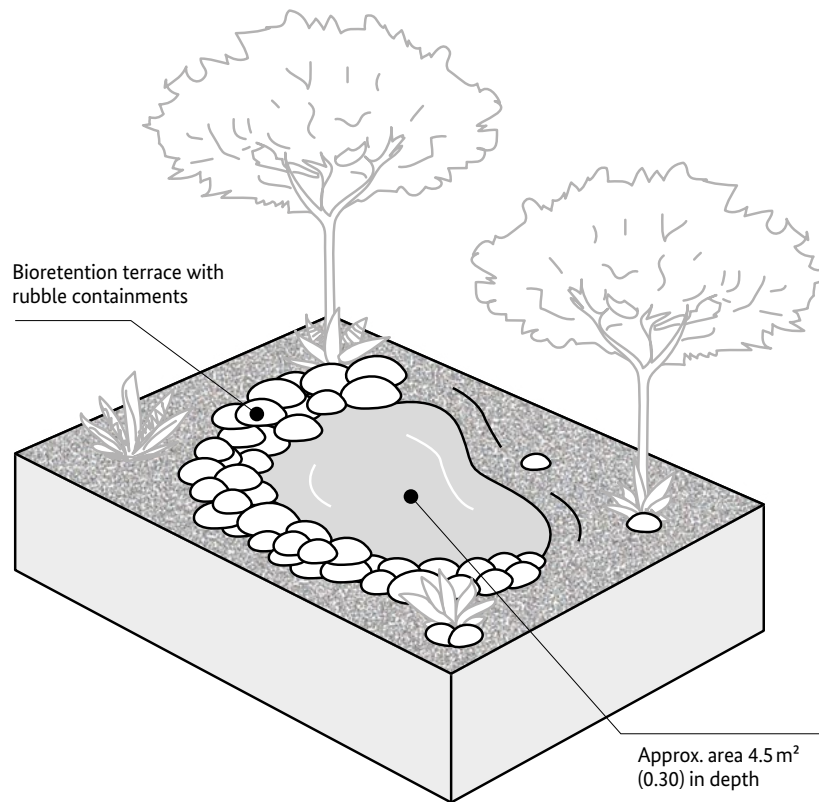

Boomerang specifications ©Alianza Oasis Urbanos.

→ Absorption/infiltration pit

Absorption/infiltration pits are pyramid-shaped, cylindrical, square or rectangular pits which increase and accelerate the infiltration of rainwater into the subsoil. The water infiltrates the soil via the permeable walls and floors of the pits.

When infiltration pits are constructed, it is recommended that they have an opening with a minimum diameter of 1 metre and a depth of between 1 and 6 metres. There are various construction

methods such as the use of masonry consisting of brick, blocks of stone or concrete with holes to allow water infiltration, and blocks of pre-cast concrete or concrete mixed at the site with good permeability characteristics. Another option is a pit without cladding which is filled with permeable materials such as medium/large rocks, pebbles and sand to maintain the stability of the walls. Such structures do not take up much space and can be used to penetrate impermeable soil layers.

INFILTRATION PIT WITHOUT CLADDING

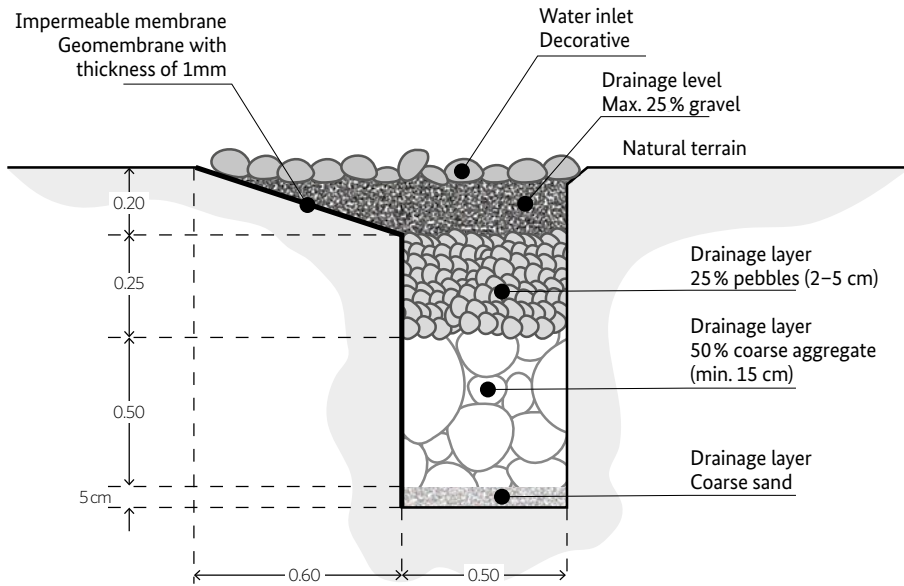
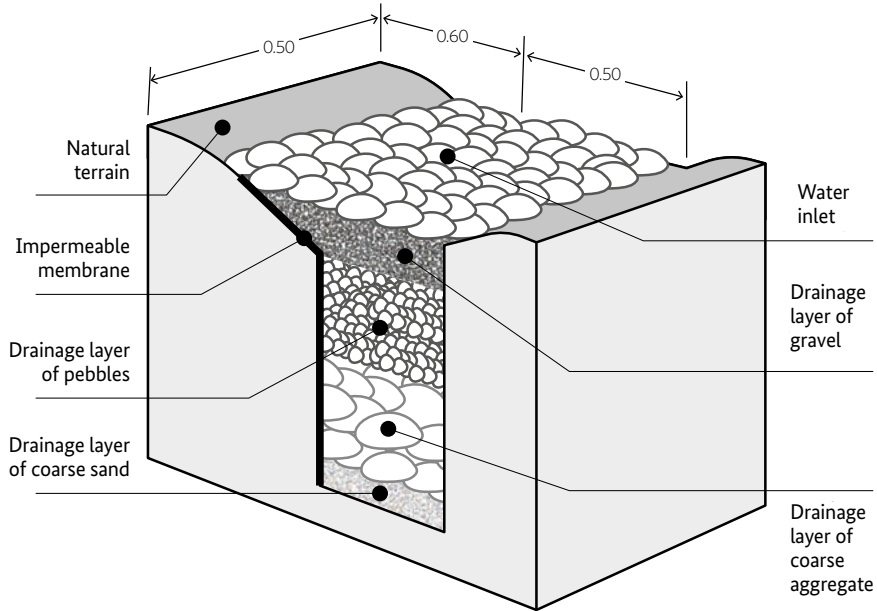

Specifications for absorption pit ©Alianza Oasis Urbanos.



Absorption pit ©Alianza Oasis Urbanos.

Seepage test

All of the GI sites must be designed to filter their maximum capacity in 24 hours to stop mosquitoes from reproducing. A seepage test can be performed to assess the speed at which water is absorbed into the earth.

→ In areas with clay-like soil or layers of caliche (an impenetrable layer of calcium carbonate which is often found in deserts), holes can be made and/or the soil can be improved using compost.

→ The use of mulch is recommended to improve filtration. For details on mulch (description, function, selection), see Annex 2. For example, 10 cm of organic mulch greatly reduces the growth of weeds. Its use is recommended in places where rainwater flows at low speed.

Adaptations to facilitate water flow

In addition to the creation of green infrastructure, other joint measures are performed to facilitate the flow of water and to prevent it from stagnating for more than 24 hours.

Curb cutting ➤ Cut-outs or openings which are made to facilitate the flow of water from an impermeable surface such as a road or car park to a ditch, hollow or planted area. These cut-outs can also act as overflows if the ditch reaches its maximum capacity, allowing water to flow in a controlled manner to the most appropriate place.

Sediment traps ➤ In areas with bare soil and a high water flow, making them susceptible to erosion, the green infrastructure must be protected using rocks or pebbles to prevent the removal of sediment. Sediment traps are an effective solution. They involve digging a hole between 50 cm and 1 metre wide and deep at the inlet where the water flows in from the permeable surface. These holes are deeper than the rest of the ditch, and they are filled with large rocks. Over time, these traps collect sediment and eventually become full, requiring maintenance.

One of the main jobs of an urban oasis is to promote community spirit and to offer learning opportunities. Through theory and practice workshops on the construction of furniture and creation of urban art, participants can discover and develop skills and contribute to a collaborative atmosphere. The ultimate aim is to make the space more appealing and to create areas for relaxation and communal life. Accompanying such spaces with gardens made up of native plants creates a pleasant atmosphere which encourages well-being, consolidates identity and invites the local residents to strengthen the social fabric of the community.

Construction of picnic areas (community use theory and practice workshop)

Urban furniture ➤ The construction of furniture in relaxation areas might include a pergola and a picnic table and benches. This allows people who visit the oasis to enjoy a shaded area where they can eat, read, chat and enjoy each other's company etc. The creation of such areas can be achieved through basic carpentry workshops during which members of the community are invited to learn a trade at the same time as contributing something to their community. At the workshop, participants learn to build simple furniture which is practical, comfortable, economical, quick to build and easy to replicate. A construction manual for the pergola and picnic table and benches can be found in Annexes 3 and 4 respectively. These guides can be printed and shared with all of the participants at the workshops.

Enhancement of the physical appearance of the site ➤ The transformation of a space using art has a dual purpose: To make the site itself more attractive and to encourage participation and active cooperation by citizens. Thanks to the interaction and the use of dialogue which can be achieved by participating in this kind of venture, strong ties can be created between members of the community. Activities which can enhance the physical appearance of the site include painting murals, benches and rubbish bins.



Community workshop on basic carpentry ©Alianza Oasis Urbanos.



Construction of urban facilities ©Alianza Oasis Urbanos.



Aerial view of the segment of pedestrian ©GIZ México, Josafat de la Toba.



Painting a pedestrian crossing ©GIZ México, Josafat de la Toba.



Mural painted by a local artist and residents ©GIZ México, Josafat de la Toba.

Signs to promote learning (theory and practice workshop)

In addition to the objective of an urban oasis being a place for enjoyment by the local community, another goal is for it to be a place of learning. This is why signs are erected with information about the importance of urban oases and their components as well as about the native species of vegetation and their characteristics, allowing users to get to know them and appreciate their function within the space.

Adaptation in line with local regulations

It is important to be aware of requirements relating to external and subterranean work in accordance with local regulations. Among other things, consideration must be given to the need for visibility by drivers, the spacing of trees on streets, and pruning near curbs and traffic lanes. The support of IMPLAN as an advisor and contact for obtaining the required permits and complying with specific rules in each area is extremely important.



Information sign about the benefits of urban oases ©GIZ México, Josafat de la Toba.



Notice about the mechanism for capturing rainwater at a bus top ©GIZ México, Josafat de la Toba.

4. Maintenance

Maintenance plan

So that the urban oasis works adequately in the long term, it is vital to involve both the community and personnel from the Municipal Public Services department of the local council in caring for and maintaining the space. The success of an urban oasis over time is dependent upon the community taking ownership of the site and, with the backing of the local council, recognising the value of keeping it in good condition. In addition, keeping the space active with various activities reinforces this sense of ownership, which in turn makes the space better cared for and safer. This invites the community to keep the oasis in good condition so that they can continue to enjoy the activities that take place there. This promotion of the use of the space reduces vandalism and encourages order and safety in the area.

To achieve this, a joint strategy between the community and public services must be developed, defining how to care for and maintain this space. It is a good idea to hold participatory workshops with workers from Municipal Public Services and a group representing the local community (such as the committee of local residents). These workshops can be used to define the roles and responsibilities of the two groups. Some of the aspects to be considered and agreed upon include a means of communication between local residents and Municipal Public Services so that everyone remains informed about important issues relating to the park, surveillance of the space, maintenance of the green infrastructure, cleaning the park, creating links between the organisers of community activities and Municipal Public Services so that the space is maintained accordingly, and identifying indicators to determine whether the space is working well.



Workshop on urban oasis maintenance and indicators ©GIZ México, Josafat de la Toba.



Measuring the dimensions of a micro-basin ©GIZ México, Josafat de la Toba.



Taking measurements for indicators of whether the urban oasis is working well, together with Municipal Public Services ©GIZ México, Josafat de la Toba.

The recommended activities for preserving the function of the park are as follows:

Irrigation:

- The plants need to be watered for an establishment period of two to three years after being planted. Thereafter, irrigation must be reduced as much as possible. Following the plant establishment period, occasional irrigation should be considered during long periods of drought (in Baja California Sur, for example, the establishment of thorough monthly watering in the hottest and driest months, so May, June, July and September, for two to three years after the period of establishment).
- Long-term drip irrigation should be considered in zones where this is necessary. Irrigation patterns which simulate those of natural rainwater can be established to provide thorough and irregular watering (this can reduce the need for maintenance by controlling the growth of the plants). Watering can also be done manually, but this depends on the judgement of the person doing the watering, and is less efficient than drip irrigation.
- Watering should take place in the evening and at dusk to minimise evaporation.
- It must be ensured that the irrigation system is working correctly.

Mulch:

- Mulch should be maintained and changed in accordance with need.
- It is recommended that the mulch be checked every year, making sure that a depth of at least 10 cm is maintained.

Growth of weeds:

- The planting of small perennial plants is recommended to reduce the growth of weeds.

Vegetation:

- Shrubs and trees must be pruned and branches must be trimmed to keep paths clear and to ensure visibility on paths. Where possible, it is recommended that trees be allowed to grow for two to three years without being pruned so that they can develop strong trunks.
- Dead plants should be replaced.

Green infrastructure:

- Rubbish and obstructions must be removed.
- It is important to ensure that water inlet and overflow areas are working properly after the rainy season. Sediment must be removed, the thin layer that forms on the surface of the soil must be raked through, stones must be rearranged and, if necessary, it must be ensured that there has been no waterlogging lasting more than 24 hours.

In the same way, it is important to determine whether the urban oasis is working well. The use of indicators which enable this to be evaluated is recommended. Although a large number of indicators exist, in this guide, we mention those which we consider (Table 1) to be feasible with the available time and resources of the Municipal Public Services and community volunteers (committee if possible):

- Capture and infiltration of water
- Establishment of vegetation
- Reduction in erosion
- Presence of shade and drop in local temperature
- Meeting of basic social needs

REMOVE RUBBISH AND OBSTRUCTIONS FROM:

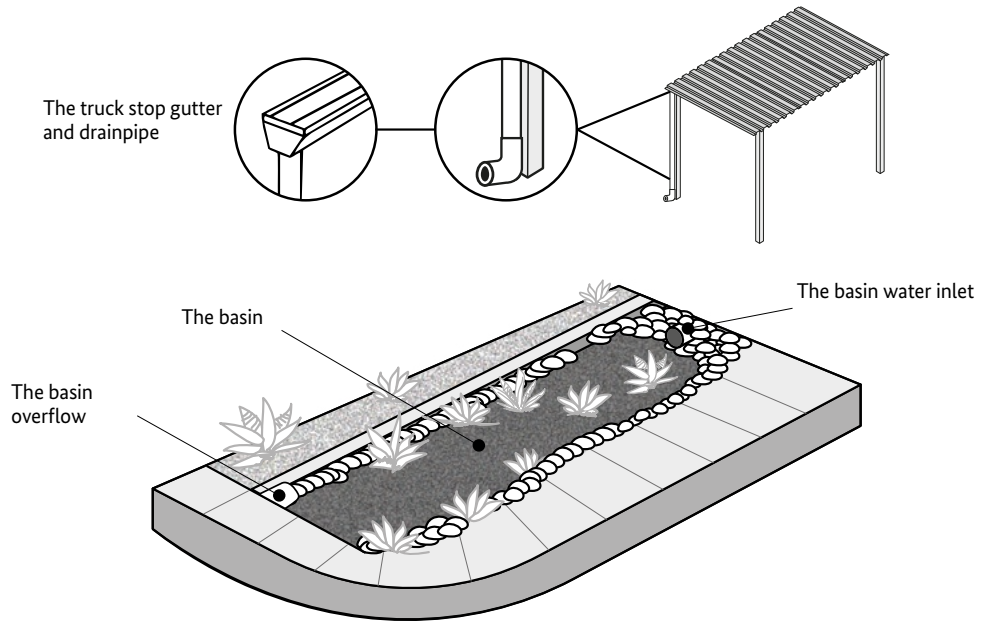

AFTER THE RAINY SEASON:

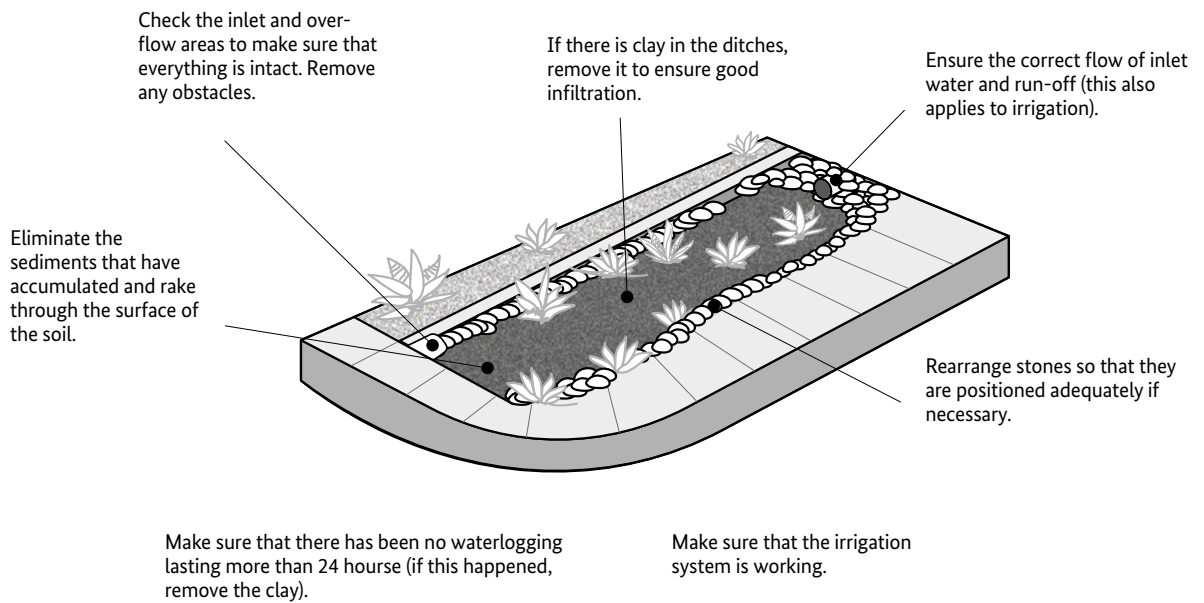

Table 2: List of indicators that the urban oasis is functioning as it should

Characteristic to observe	Indicator	Justification	Method
Vegetation	Number of individual plants per basin	Areas with urban vegetation have an impact on moisture and water infiltration. They control erosion, regulate temperature and trap atmospheric pollutants.	Servicios Públicos Municipales contarán el número de los individuos de vegetación por cuenca. Éstos deben ir aumentando con el tiempo.
Capture and infiltration of water	Depth of the basin	The depth of the basin should be between 30 and 50 cm so that it can adequately retain water.	Municipal Public Services will check that the depth of the basin is between 30 and 50 cm. If the depth is maintained, the basin is adequately capturing water.
	Accumulated water quantity	All of the GI sites must be designed to filter their maximum capacity in 24 hours to stop mosquitoes from reproducing.	The committee of local residents will check whether water is accumulating in the basins and remaining for more than 24 hours. If this happens, water infiltration is insufficient, and appropriate maintenance measures must take place.
	Thickness of mulch layer	Because potential evaporation greatly exceeds precipitation in desert areas, the use of mulch is essential. This reduces the evaporation of soil moisture.	Municipal Public Services will check that a mulch layer of at least 10 cm is maintained. If the thickness of the mulch layer decreases, evapotranspiration means that less water will infiltrate the ground than would otherwise be the case.

Characteristic to observe	Indicator	Justification	Method
Erosion	Accumulated sand quantity	Once vegetation becomes established, there will be more soil retention and erosion will decrease.	The committee of local residents will take photos for comparison purposes of sites where sand accumulates. If no sand is accumulating, this indicates that the soil is being adequately retained.
Shade	Amount of shade (coverage)	Tree coverage is extremely important when it comes to climatic adaptation. This is because trees generate shade, which helps to mitigate exposure to high temperatures. If vegetation cover increases, the temperature will drop.	The committee of local residents will take photos for comparison purposes of sites with tree coverage so that the development of shade can be monitored over time. The more the vegetation develops, the more shade there will be, which will cause the local temperature to drop.

The monitoring of any increase in wildlife and pollinators, the number of people who visit the park, and the activities that take place there is also recommended.

Since community involvement, a shared vision and a sense of belonging give rise to community engagement, it is important to take the following points into account:

→ Establish an atmosphere of coexistence and a shared strategy between the community and Municipal Public Services.

→ Consider environmental conditions (such as extreme heat) in which Municipal Public Services carries out activities in the parks in order to bring about better maintenance results.

→ The involvement of Municipal Public Services in workshops where participants can learn new skills which can be used during work at the parks (e.g. workshops about native plants and fauna etc.) is desirable.

Cost of an Urban Oasis

The costs of an urban oasis can vary depending on the goals, characteristics of the specific space and the implementation site. This manual lists and describes the most important concepts to be costed for the implementation of the urban oasis (→ Tabla 3).

Of the concepts listed above, the most costly are the initial planning, green infrastructure and – depending on the site – the native vegetation.

It is important to consider the fact that creating collaborative relationships with various people, groups, organisations and institutions can lead to people providing in-kind support, which can help to reduce costs. For example, during the realisation of urban oases, we have benefited from transplanted trees from the local council, small trees from the Forestry Development Office and paint donated by companies wishing to support the project, among other things.



Rainwater that does not infiltrate and flows towards the Bay of La Paz
©Miguel Ángel de la Cueva / Sociedad de Historia Natural Niparajá

Tabla 3: List of concepts

Activity	Description
Initial planning	Architectural design, topographic survey, advice on regenerative construction
Preparatory work	General cleaning of the terrain, loading and transport of the material collected during cleaning work
Green infrastructure	Basin surrounded by stone slope
	Boomerang surrounded by stone slope
	Absorption pit with various layers made up of differently sized materials in order to store water
	Discharge channel to provide an outlet if the system becomes saturated
Relaxation and paths module	<p>Layout and topographic levelling, casting of concrete blocks for metal anchors of pergola</p> <p>If handmade bricks are to be laid: Formation and compaction of embankments with material from the site, perimeter ridge to confine the brick flooring/paving stones or similar, laying of the bricks, concrete flooring</p>
	Materials for the construction of urban furniture (pergola, table, bench)
Signs	A large 60x40 cm sign with general information about urban oases
	Signs describing the native vegetation species
Native vegetation	Large and small trees and shrubs
Theory and practice workshops	<p>Realisation of 6 workshops: (1) Design of the space; (2) Reforestation with native vegetation; (3) Green infrastructure; (4) Creation of areas for communal use; (5) Urban art; (6) Water and other topics for which raising awareness is considered important, with a maximum duration of three days for each workshop.</p> <p>It is important to consider the cost of renting a space for the workshops, if required, along with tables, chairs, awnings, food for the participants, stationery etc.</p>
Human resources	Project coordination team to be responsible for checking that the project is being executed correctly at each stage and that all desired results are generated. This team should also be involved in the participatory workshops.

Annexes





Annex 1 – The 12 criteria

12 Quality Criteria

Step by step

Description

The format of the twelve quality criteria is structured around three main topics: Protection, comfort and enjoyment.

First, without protection from cars, noise, rain and wind, people generally tend to avoid spending time in a space. Protection against these elements is essential to ensuring that the space is used regularly.

Second, a place without elements which make walking, standing, sitting, and seeing and conversing with others a comfortable experience will not attract people to it. A space with options for play and possibilities for exercise will be more appealing to a more diverse public.

Finally, outstanding public spaces generally offer a positive sensory and esoteric experience. They make the most of local climatic conditions (e.g. by offering shade in hot places) and provide elements on a human scale so that visitors do not feel lost in their surroundings.

Instructions

Choose your site: This tool works for different types of public space: Squares, parks, blocks and streets. You cannot expect there to be a strong establishment of public life in all parts of a city, so you should choose a site which you think is appropriate for the use of this assessment. Once a site has been selected, consider it within a wider network of public spaces.

Spaces with a low level of activity are not necessarily less useful for this tool. Remember that ground floor spaces with active uses can play an important role in a good public space.

Plan the activity well: The questionnaire will be more useful on a busy day with good weather. However, it can be carried out at any time and on any day of the week, since the variables being evaluated do not change much.

Prepare well: Take a clipboard, pen or marker, and wear clothes suitable for the weather.

When you arrive at the site, spend five minutes just looking around. This evaluation is not timed, but it is important to understand the space before carrying out the exercise. Depending on exactly where you are, you can obtain different quality criteria. Start with the spaces with more people and proceed as you see fit.

If more than one person is asking questions: Make sure that you complete the exercise individually and then meet at the end to discuss and compare results.

The observers evaluate and take notes on the public space and determine whether it meets the criteria. Give a value to each criterion: A smiley, neutral or sad face in each case (representing “yes”, “somewhat” or “no”).





12 Criteria of Urban Quality

😊 = Yes
 😐 = Somewhat
 ☹️ = No

Location:

Protection	<p>Protection against traffic and accidents.</p> <p>Are there road safety measures in this space to protect groups of different ages and abilities? Can you ride a bike or walk without fear of being knocked over by a driver?</p>	<p>Protection from harm by others.</p> <p>Does the space feel safe both during the day and at night? Are people around and do activities take place all day long because, for example, the area has a mixed residential and commercial use? Does the lighting make people feel safe and create a pleasant atmosphere at night?</p>	<p>Protection against unpleasant sensory experiences.</p> <p>Is there any noise, dust, bad smells or other type of pollutant? Does the public space function well if it is windy? Is there shelter from the sun, rain and minor flooding?</p>
Comfort	<p>Options for mobility.</p> <p>Is this space accessible? Are there physical elements which might limit personal mobility when people are trying to walk around, use a wheelchair or push a pram? Are pathways for moving around clear with no need to make illogical diversions?</p>	<p>Options to stand and linger.</p> <p>Are there elements such as an interesting façade, bus stop, bench, tree or some kind of niche where people can spend a moment recharging their batteries?</p>	<p>Options for sitting.</p> <p>Are there attractive seating elements such as benches or chairs? Or are there only secondary elements such as steps, a wall or the edge of a fountain? Are there adequate non-commercial seating options where you do not have to pay in order to sit down?</p>
Enjoyment	<p>Options for seeing.</p> <p>Are the seats arranged so that there are interesting elements to look at whilst you're sitting down?</p>	<p>Options for talking and listening/hearing.</p> <p>Can you chat in this space? Can you see any spaces where you can sit with others and talk to them?</p>	<p>Options for play, exercise and activities.</p> <p>Are there options for taking part in activities at different times of the day and year?</p>
Enjoyment	<p>Scale.</p> <p>Are the surroundings on a human scale? If there are people on the edges of the space, can you still interact with them as other people or do they get lost in their surroundings?</p>	<p>Opportunities to enjoy positive aspects of climate.</p> <p>Have local climatic factors such as wind and the sun been taken into account? Are there varying conditions for spending time in the space at different times of the year? Taking this into account, where are the options for sitting down? Are they completely in the sun or in the shade? How are they positioned in relation to the wind? Are they protected?</p>	<p>Experience of aesthetic qualities and positive sensory experiences.</p> <p>Is this public space attractive? Is a good design evident (both in terms of form and durability)?</p>

Annex 2 - mulch

“Mulch” means any substance that is used to cover and protect the soil.

- Organic mulch: This is made up of dried and crushed pieces of plants.
- Living mulch: Vegetation grown to cover the soil.
- Rock mulch: This is made up of pebbles, stones, concrete or broken-up brick.

Function:

One of the main jobs of mulch in green infrastructure is to reduce the evaporation of the moisture in the soil. This job is vital in desert areas where the potential evaporation (e.g. 1,467 mm in La Paz) greatly exceeds precipitation (165 mm in La Paz).

Function, costs and benefits of organic mulch and of rock/pebbles

	Organic mulch	Rock/pebble mulch
Weed control	Yes	Somewhat
Soil moisture retention	Yes	Somewhat
Soil temperature control	Yes	No
Formation of organic material in soil	Yes	No
Reduction in erosion	Yes	Yes
Remains in place in areas with a high water flow	No	Yes
Provision of a wildlife habitat	Yes	Somewhat
Requirement for cleaning up of fallen leaves	No	Sometimes
Renewable, contributor to low carbon footprint	Yes	No
Addition of beneficial microbes to soil	Yes	No
Cost	Low/free*	Higher

*Companies which prune trees sometimes give away dead leaves for free.

Selection and design of site

The use of organic mulch is preferable whenever possible due to its many advantages. The main advantage of rock mulch is that it does not move in areas where there is lots of pedestrian traffic or a significant flow of rainwater.

Taking these factors into account, the general rule for selecting mulch is as follows:

- Use organic mulch in areas prone to waterlogging such as ditches near cut-offs in curbs.
- Use rock mulch in areas with water flow or where flooding might be problematic, e.g. in hollows or installations in the street.

Other things to bear in mind when using mulch:

- An organic mulch layer of at least 10 cm should be maintained in order to effectively reduce the growth of weeds.
- Keep the mulch away from the trunks of trees and shrubs to prevent rotting.
- Do not use broken-up material or pebbles which have not been washed in or near filtration areas, since small particles can clog the pores of the soil and prevent filtration.
- Use larger, tightly packed stones (10–20 cm or larger) to reduce erosion in places where flooding might be problematic.



Mulch in the botanic garden area ©GIZ México, Josafat de la Toba.



Annex 3 – pergola installation manualde pérgola

The pergola installation manual can be printed out as a leaflet and given out at the furniture construction workshop.

STEP 1:
INSTALLATION OF CORRUGATED ROOF
Fasten the Opalite sheets to the top of the beams using the 1" self-tapping screws.

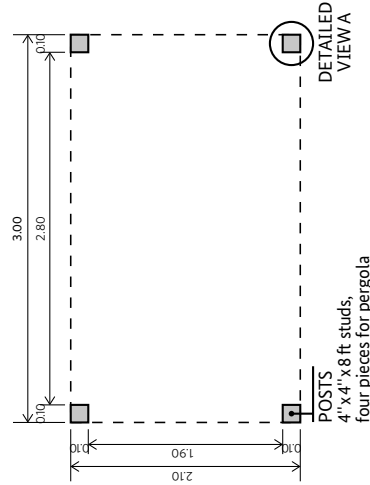

STEP 2:
PLACEMENT OF BEAMS
Place the beams at the highest point of each post and fasten the beams to the posts with the hex head screws for wood (1/4" x 3 1/2").

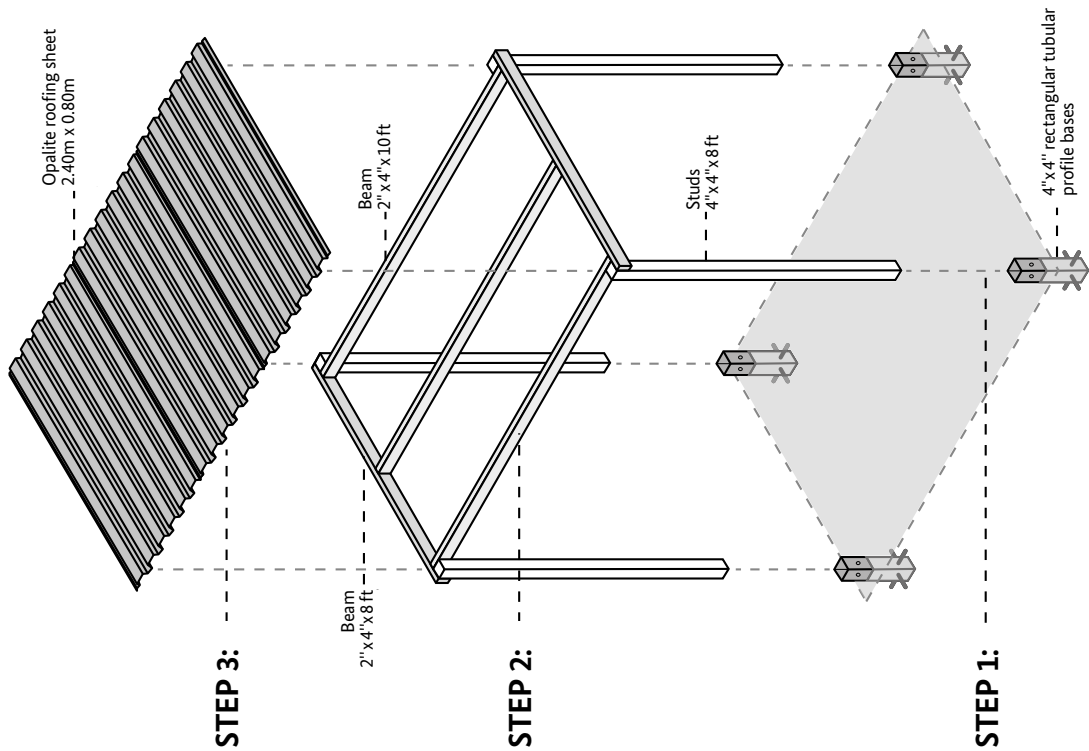
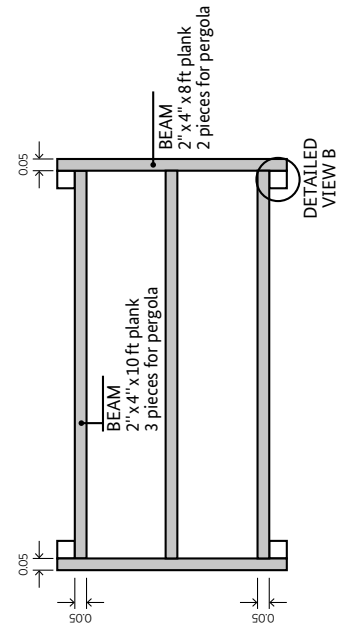

STEP 3:

INSTALLATION OF CORRUGATED ROOF

Fasten the Opalite sheets to the top of the beams using the 1" self-tapping screws.

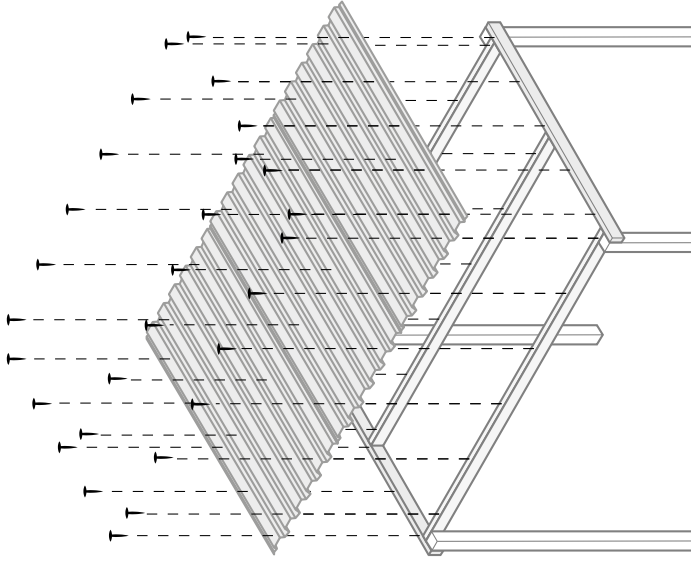

MATERIALS

Four 4"x4" rectangular tubular profile bases (anchors) / four 4"x4"x8ft studs (posts) / one 1/2"x1m worm screw with nut and washer, eight 1/2" washers and eight 1/2" nuts / twenty 1/4"x3 1/2" hex head screws for wood / three 2"x4"x10ft planks (beams) / two 2"x4"x8ft planks (beams) / four 2.40m x 0.80m Opalite roofing sheets / fifty 1" self-tapping screws for wood

Installation manual Pergola

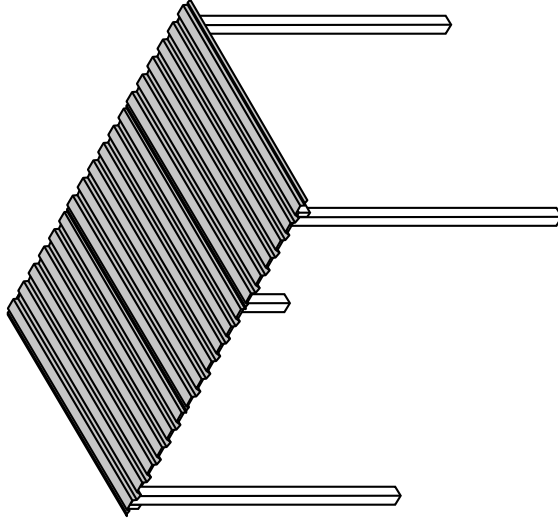

alianza_oasisurbanos
#alianzaOasisUrbanos
alianza.oasisurbanos@gmail.com





Annex 4 – Picnic table installation manual

The picnic table installation manual can be printed out as a leaflet and given out at the furniture construction workshop.

STEP 1

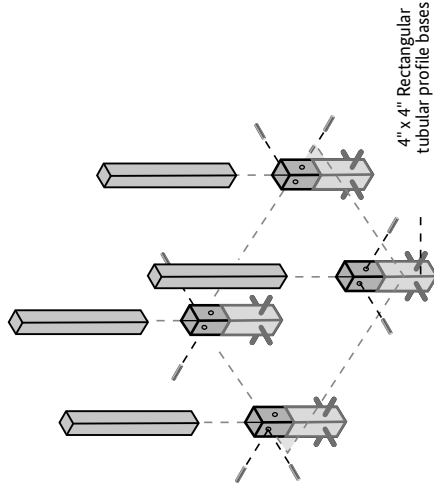

MATERIALS

- Four 4"x4" rectangular tubular profile bases (anchors)
- Four 4"x4"x0.85m studs (posts)
- Four 2"x4"x1.76m planks (beams)
- Four 2"x4"x0.8m planks (beams)
- Ten 2"x6"x2.05m planks
- Six 1/4"x2 1/2" hex head screws for wood
- 125 1/4"x3" hex head screws for wood
- Transparent, water-based varnish (glossy)
- Brushes / black spray paint

STEP 1:

POST POSITIONING AND PLACEMENT

Cut the worm screw into eight 12.5 cm pieces. Place the 4"x4" studs into the rectangular tubular profile bases and fasten them to the bases using the screws, nuts and washers.

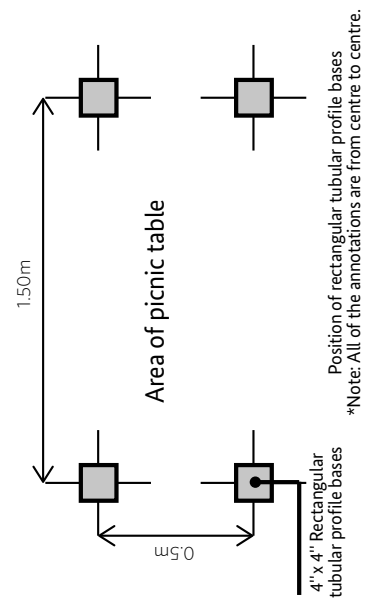

STEP 2:

PLACEMENT OF BEAMS

Place the 0.80m beams (2"x4"x0.80m planks) at the highest point of each post and the 1.76m beams (2"x4"x1.76m planks) at a height of 0.412m. Fasten the beams to the posts with the 1/4x3" hex screws for wood.

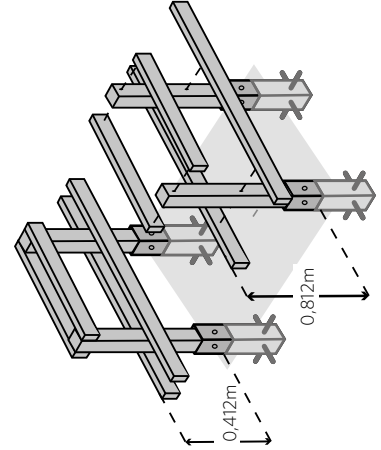



URBANERÍA



STEP 3:

PLACEMENT OF TABLE AND SEATS

Fasten the 2" x 6" x 2.05m planks to the beams with the hex head screws for wood.

Installation manual Picnic table

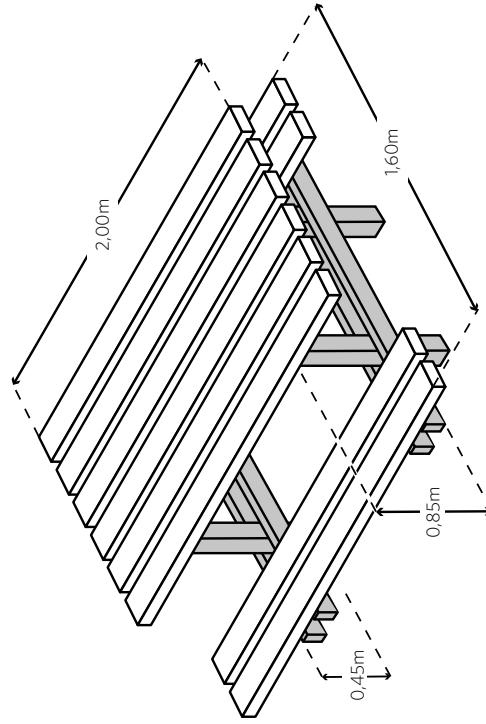
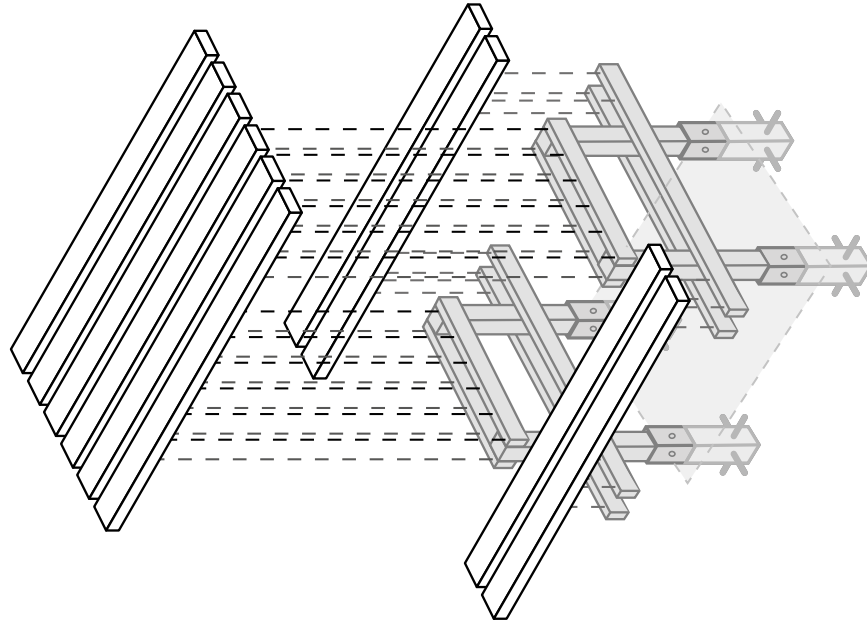

alianza_oasisurbanos
#alianzaOasisUrbanos
alianza.oasisurbanos@gmail.com







[alianza_oasisurbanos](#)

[#alianzaOasisUrbanos](#)



alianza.oasisurbanos@gmail.com